

# Installation Instructions for Model CL Clustered Skydome Units



**SAFETY CONSIDERATIONS:** WASCO SKYLIGHTS ARE DESIGNED TO WITHSTAND NORMAL ELEMENTS OF THE WEATHER. THEY ARE NOT DESIGNED TO WITHSTAND HUMAN IMPACT OR FALLING OBJECTS. THESE SKYLIGHTS SHOULD NOT BE WALKED UPON UNDER ANY CIRCUMSTANCES. THE OWNER OR DESIGNER SHOULD RESTRICT ACCESS ONLY TO AUTHORIZED PERSONNEL WHO HAVE BEEN ADEQUATELY CAUTIONED AS TO THE LOCATION OF THE SKYLIGHTS AND INFORMED OF THE WARNING ABOVE, OR SAID OWNER SHOULD PROVIDE PROTECTIVE GUARD RAILS OR SCREENS AROUND THE SKYLIGHT.

**SCOPE:** These installation instructions cover the field installation of WASCO model CL CLUSTERED SKYDOME UNITS. These installation instructions are to be used in conjunction with the submittal drawings or data sheet(s) for unit dimensions, and specific field conditions.

**NOTE:** Before starting installation, read entire installation instructions and review submittal drawings or data sheet(s) in order to become familiar with the installation procedure of this unit, and specific jobsite conditions on this project.

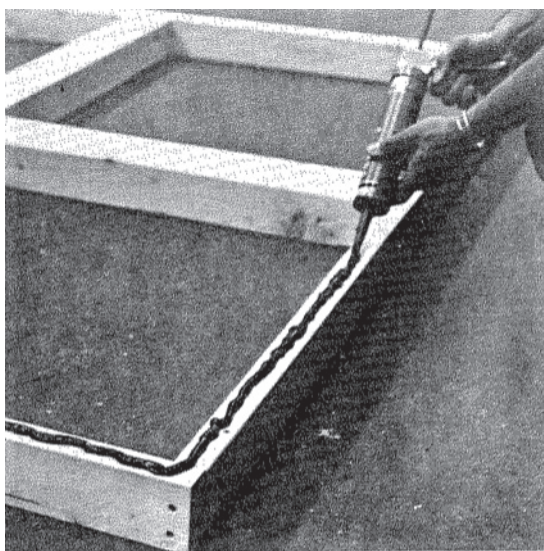

**STEP-1:** Before installation of unit, ensure that the building curb has been properly prepared to receive unit. Place a bead of sealant on top of flashed building curb (see illustration at left, flashing omitted for clarity).

**STEP-2:** Install perimeter sill onto building curb. Do not secure. Note: ensure that weep holes are on low side of unit (see illustration below).

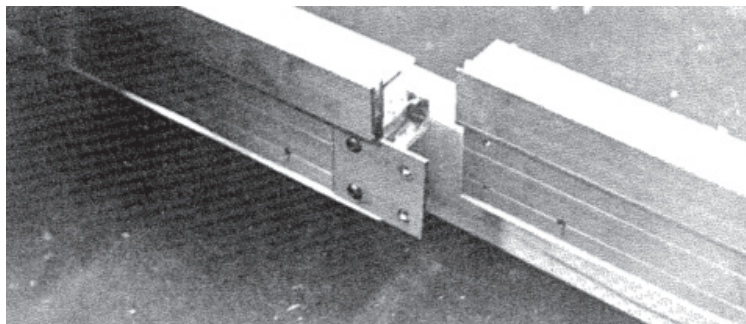

**STEP-3:** Install aluminum channels for rafter bars. Ensure that centerline of channel aligns with centerline of support and scribe mark on sill. Secure aluminum channels with 1/4" dia. X 1 1/2" stainless steel lag bolts (not provided by Wasco).

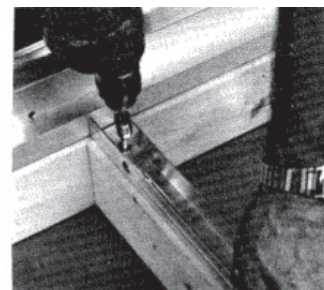
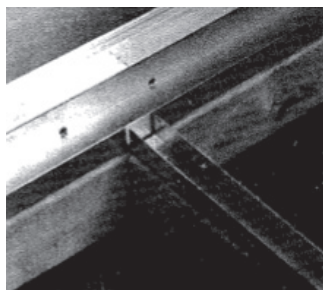

**STEP-4:** Install aluminum channels for purlin bars. Ensure that centerline of channel aligns with centerline of support and that ends of channels are 1/2" away from face of rafter channels. Secure Aluminum channels with 1/4" dia. X 1 1/2" stainless steel lag bolts (not provided by Wasco).

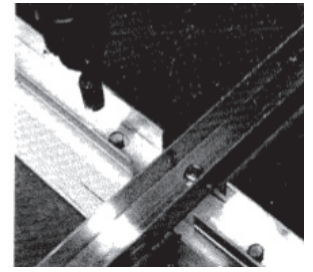
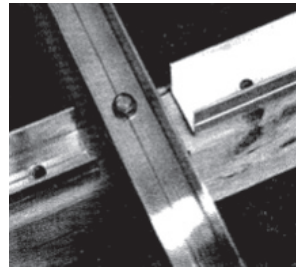

**STEP-5:** Install rafter bars over rafter channels. Ensure that centerline of rafter bar aligns with scribe on line on sill. (see illustration below). Install purlin bars over purlin channels. Ensure that centerline of purlin aligns with scribe line on rafter bar. (see illustration below). Fasten rafter and purlin bars with #14 x 1 self-drill/self-tap screws thru predrilled holes in rafter and purlin bars.

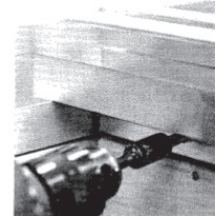
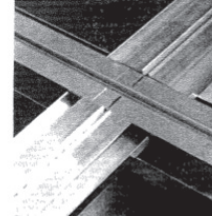
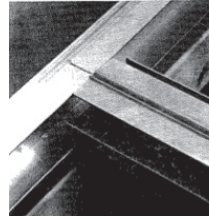

**STEP-6:** secure plates to perimeter sill with #10 X 5/8" stainless steel truss head sheet metal screws.

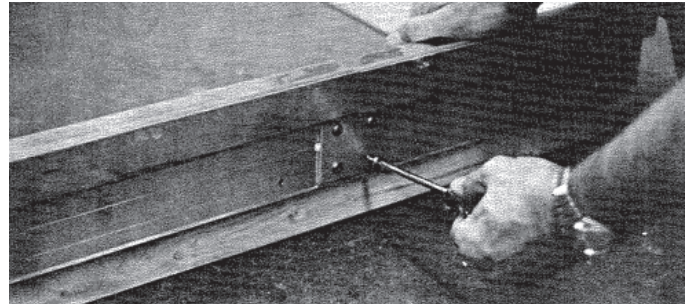

**STEP-7:** Anchor perimeter sill to building curb with 8d stainless steel or galvanized nails (not by WASCO).

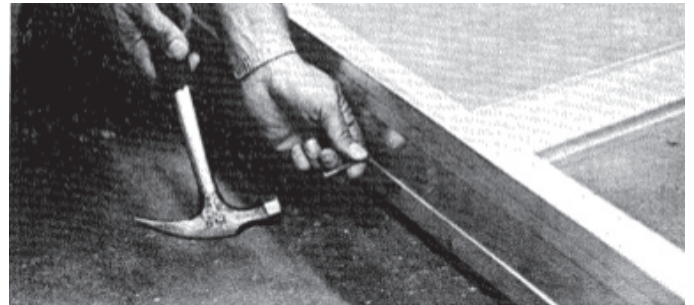

**STEP-8:** Apply silicone sealant at interior of all perimeter sill splice locations.



**SAFETY CONSIDERATIONS:** WASCO SKYLIGHTS ARE DESIGNED TO WITHSTAND NORMAL ELEMENTS OF THE WEATHER. THEY ARE NOT DESIGNED TO WITHSTAND HUMAN IMPACT OR FALLING OBJECTS. THESE SKYLIGHTS SHOULD NOT BE WALKED UPON UNDER ANY CIRCUMSTANCES. THE OWNER OR DESIGNER SHOULD RESTRICT ACCESS ONLY TO AUTHORIZED PERSONNEL WHO HAVE BEEN ADEQUATELY CAUTIONED AS TO THE LOCATION OF THE SKYLIGHTS AND INFORMED OF THE WARNING ABOVE, OR SAID OWNER SHOULD PROVIDE PROTECTIVE GUARD RAILS OR SCREENS AROUND THE SKYLIGHT.

**STEP-9:** before installing any acrylic domes, thoroughly clean all surfaces. Refer to information below.

### HOW TO CLEAN THE ACRYLIC DOMES, WASCO CLUSTERED SKYLIGHTS

1. Clean with liquid detergent such as Ivory, Joy, etc., and water. Use soft cloth, sponge or chamois. (often surfaces can be lightly dusted with a soft clean cloth, and then wiped with a soft, wet cloth or chamois).
2. Grease and oil spots can be removed with kerosene or VM&P naphtha. Caution: Other detergents, cleaners and solvents may harm acrylic.
3. Use only the above cleaning methods or approved cleaners. The following are some approved cleaners:

Surfire Plastic Cleaner:  
Surfire Products Company  
6423 Bandini Blvd  
Los Angeles, CA

Permatex Plastic Cleaner:  
Permatex Company, Inc  
PO Box 1350  
West Palm Beach, FL

4. Also, for cleaning, polishing, and providing an anti-static surface, the common household cleaner "Johnson's Pledge" is very effective.

**STEP-10:** Pre-apply 1/4" x 5/8" structural glazing tape to sill (Caution must be exercised in the tape placement as once the adhesive contacts the mounting surface, it becomes difficult to adjust or remove. place inner domes over frame. Wet seal inner dome to frame with a continuous bead of silicone tooled in place.

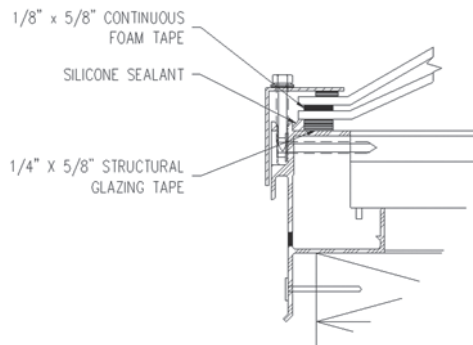

For double domes, apply 1/8" x 5/8" continuous foam tape around perimeter of inner dome. Place outer dome over inner domes.

Refer to drawing for dome identification marking and location. Ensure that domes are spaced evenly over each frame opening.

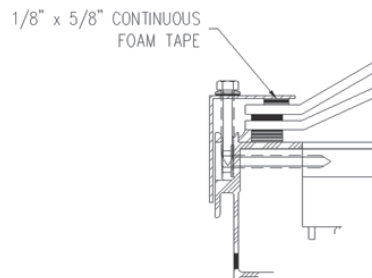

**STEP-11:** Place 1/8" x 1/2" butyl sealant tape on perimeter retainers.



**SAFETY CONSIDERATIONS:** WASCO SKYLIGHTS ARE DESIGNED TO WITHSTAND NORMAL ELEMENTS OF THE WEATHER. THEY ARE NOT DESIGNED TO WITHSTAND HUMAN IMPACT OR FALLING OBJECTS. THESE SKYLIGHTS SHOULD NOT BE WALKED UPON UNDER ANY CIRCUMSTANCES. THE OWNER OR DESIGNER SHOULD RESTRICT ACCESS ONLY TO AUTHORIZED PERSONNEL WHO HAVE BEEN ADEQUATELY CAUTIONED AS TO THE LOCATION OF THE SKYLIGHTS AND INFORMED OF THE WARNING ABOVE, OR SAID OWNER SHOULD PROVIDE PROTECTIVE GUARD RAILS OR SCREENS AROUND THE SKYLIGHT.

**STEP-12:** Install perimeter retainers. Fasten with 1/4-20 hex head machine bolts with gasketed washers.

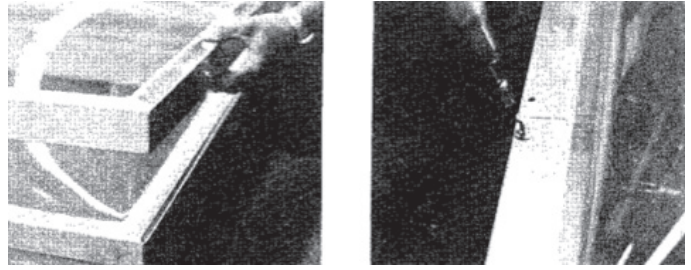

**STEP-13:** Install main rafter caps. Fasten with 1/4-20 hex head machine bolts with gasketed washers.

**STEP-14:** Install purlin caps between rafters. Fasten with 1/4-20 hex head machine bolts with gasketed washers. Apply silicone to ends and seal to rafter caps.

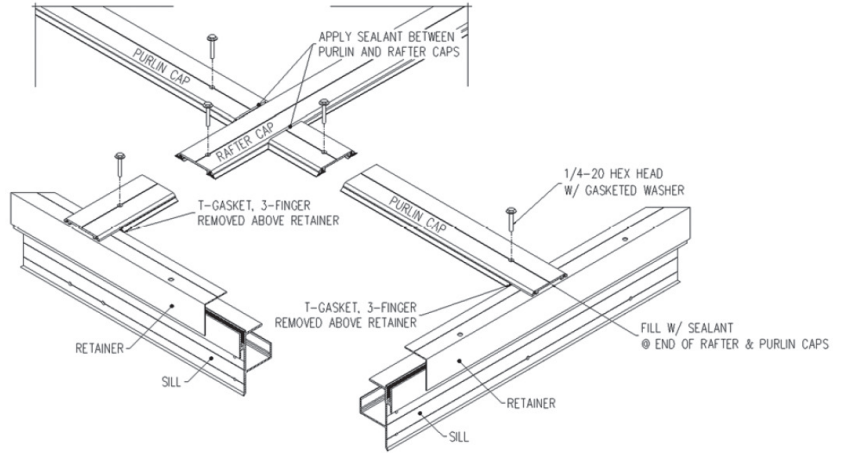

**STEP-15:** After unit has been completely fastened, proceed to seal all joints with sealant.

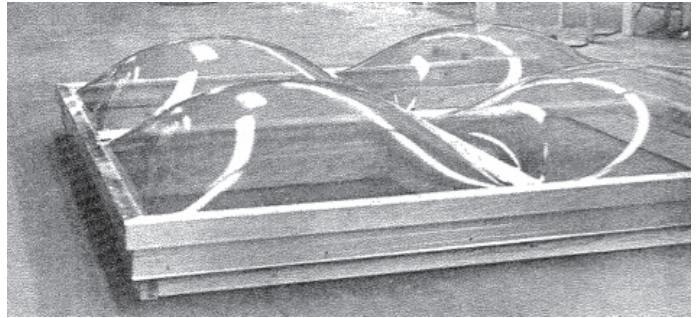

**THIS COMPLETES MODEL CL CLUSTER SKYDOME UNIT INSTALLATION**



**SAFETY CONSIDERATIONS:** WASCO SKYLIGHTS ARE DESIGNED TO WITHSTAND NORMAL ELEMENTS OF THE WEATHER. THEY ARE NOT DESIGNED TO WITHSTAND HUMAN IMPACT OR FALLING OBJECTS. THESE SKYLIGHTS SHOULD NOT BE WALKED UPON UNDER ANY CIRCUMSTANCES. THE OWNER OR DESIGNER SHOULD RESTRICT ACCESS ONLY TO AUTHORIZED PERSONNEL WHO HAVE BEEN ADEQUATELY CAUTIONED AS TO THE LOCATION OF THE SKYLIGHTS AND INFORMED OF THE WARNING ABOVE, OR SAID OWNER SHOULD PROVIDE PROTECTIVE GUARD RAILS OR SCREENS AROUND THE SKYLIGHT.